

**Final Report**  
*Development of Video Techniques*  
*for*  
*Bycatch Reduction Study*

**Captain Bill Lee**  
**Allan Michael, Ph.D**

**April 15, 2004**

---

#EA133F-02-SE-0187

## **Narrative**

The purpose of this project was to develop video techniques for use in fisheries research and provide a detailed manual so that other fishermen and researchers could construct similar gear.

Bycatch remains a contentious issue in commercial fishing and also in research efforts. Many fish die in studies of gear performance and selectivity. A major task was to build a cod end video quantifier which would allow nets to be towed and fish to be identified and counted as they were released unharmed. The quantifier consisted of a 48 inch by 30 inch steel tube with a camera in the middle of one side. Two tubes were designed. One out of steel mesh, and a second out of plastic. The quantifier was installed at the end of the cod end on seven different fishing vessels. Six of the vessels had chain sweeps and one had a disc sweep. Tows were performed in depths ranging from 5 fathoms to 55 fathoms. Both incandescent and LED lights were then added to improve video quality.

An ordinary lollipop was attached to a spring which held the cod end closed. Twenty-two different hard candies were placed in salt water and the time it took for them to dissolve was recorded. Times ranged from 28 – 55 minutes. When the lollipop dissolved, the fish were released from the cod end virtually unharmed. A tethered camera was attached to the headrope and a self-contained High-8 camera was placed in various locations to observe fish escaping. A light source and measuring board was fitted into the tube so that fish could be counted and measured. Out of approximately 5,000 lbs. of fish that traveled through the gear in twenty five 30-minute tows, less than 50 lbs. were dead or damaged.

In tows on the sandy sediments found in areas shallower than 30 fathoms, fish could be clearly seen exiting through the cod end quantifier. At depths below 30 fathoms, mud plumes were seen on the bottom half of the video tape. There was too much mud to be able to count and identify fish. In an effort to raise the fish in the net above the mud plume, a ramp was installed at the base of the net at the entrance of the quantifier tube. Black and white cameras were aimed at the ramp to observe what happened to the fish. The ramp did not work properly because fish were getting stuck in the crevasse where the ramp met the quantifier. In a further development, floats were added to attempt to lighten and get some lift on the cod end. One float was added at 75 fathoms back, then at 30 fathoms. Two more floats were added. On a third tow 1.5 floats were added at 22 fathoms. The addition of floats proved to be of little help in raising the cod end off the bottom.

A further task on the project was to design a basket to weigh multi-species discarded bycatch. A basket, approximately the size of a standard fish basket was fabricated out of steel wire mesh. The basket was designed to work in conjunction with video cameras on deck. The cameras were linked to the boat's GPS so that twelve functions listed (below) could be recorded. A data logger was attached to the net and another was used for surface temperature. The loggers recorded time, temperature and

depth, and were used to get a simple, accurate catch-per-unit effort by showing how long the gear was on the bottom.

Data parameters collected in the CPUE were:

- Date
- Set-out time
- Coordinates
- Speed
- Heading
- Catch
- Volume of catch
- Total weight of discard
- Surface and bottom temperatures
- Salinity
- Depth
- Haul-back time

The basket had an escape hatch at the bottom to allow for emptying when full. The unit was hung overboard with a 100 lb. scale to record the weight of bycatch. A measuring board was installed vertically in the basket to measure volume. Basket tests for this project were conducted for a period of six months from August 2003 until February 2004.

Lighting is a significant issue in underwater video work and a variety of tests were performed to solve some of these problems. A baited underwater video was set up with both incandescent and LED lights facing down directly above the bait. Switches enabled the observer to turn on either light source. The light remained off until a fish was observed. When an incandescent white light was turned on, fish would immediately scatter. When the LED light was turned on there was little or no reaction. LED lights emit a cooler light and we believe it is possible they appear to marine life as natural light sources such as the moon and stars that penetrate from the surface. LED lights should be considered where fish will react to the light source.

Light tests were conducted using a light meter to determine the LUX and foot-candles of different colored LED and incandescent lights. Where colored lights were not available, filters were used. These included violet, blue, green, yellow, orange and red, as well as clear and white. Previous studies have shown that blue lights penetrate the deepest and red lights penetrate the least. Another advantage of LED lights is the lower voltage draw which means that self-contained systems can remain active for much longer.

The project was notable for a great deal of interest generated among the fishing community and outstanding cooperation from participating and non-participating fishermen. Fishermen's participation was encouraged and their suggestions were incorporated into the program. A number of fishermen had their gear examined by video camera while under tow. The gear observed included:

of other parameters. This will provide an accurate assessment of CPUE and total bycatch for each trawl. In a fleet of boats working an area, one vessel could have an observer counting and identifying individual bycatch species. If all other vessels in the area provide total weight (unsorted) of bycatch, the overall impact of bycatch discard would be better understood.

4. Tests of lighting systems which indicate that LED light sources are more appropriate for studies where fish behavior is an issue. Brighter incandescent lights are suitable for observing gear.
5. A fleet of eleven fishing boats with captains who have been trained to collect scientific data. Nine boats were issued a basket, scale, measuring board and a temperature recorder. This equipment stayed with the boats after the project ended and the fleet has since been involved in two other federally-funded research efforts using this gear.
6. We produced a video, "Introducing Fishermen to Marine Research Equipment", which was distributed to over 70 fishermen and other interested parties, including Gloucester and Rockport sciences classes from 3rd - 12th grades. This video is still available to anyone requesting it.
7. Captain Bill Lee gave a presentation to the American Fisheries Society, where he was able to share information on the development of the cod end quantifier and the use of an ordinary lollipop to reduce fish mortality while conducting marine research.
8. Establishment of a website ([www.cafi.info](http://www.cafi.info)) which features the results of this and other studies. The site is interactive and has received many enquiries from fishermen and others.

# UNDERWATER VIDEO EQUIPMENT & TECHNIQUES

CAPTAIN BILL LEE  
F/V OCEAN REPORTER  
ROCKPORT, MASSACHUSETTS

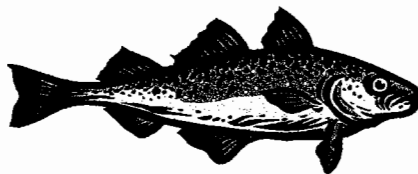

APRIL 2004

## INTRODUCTION

New technology has made underwater video both available and affordable for fishermen and researchers. What used to take years of gear testing, can now be tested in days because of direct observation using advanced underwater video technology. With the right underwater camera equipment most marine life in the Gulf of Maine can be observed. This allows us to continue collecting the data necessary to maintain the Gulf of Maine fisheries. Most marine life will react to the cameras, lights and tethers in some way, but this can be minimized if the right techniques and equipment are used.

We begin with underwater lighting. I started out using cameras without additional lights and had some success. Then I began to experiment with lighting and soon learned that with more light I could get much better video. However, the fish were reacting to the lights, so now we had another problem which can be minimized with the right lighting (LED lights and bright sunlight). The best camera only works as well as the light it receives.

As you read through this manual, equipment resources will be in parenthesis. All of these resources, as well as many others, can easily be found on the internet.

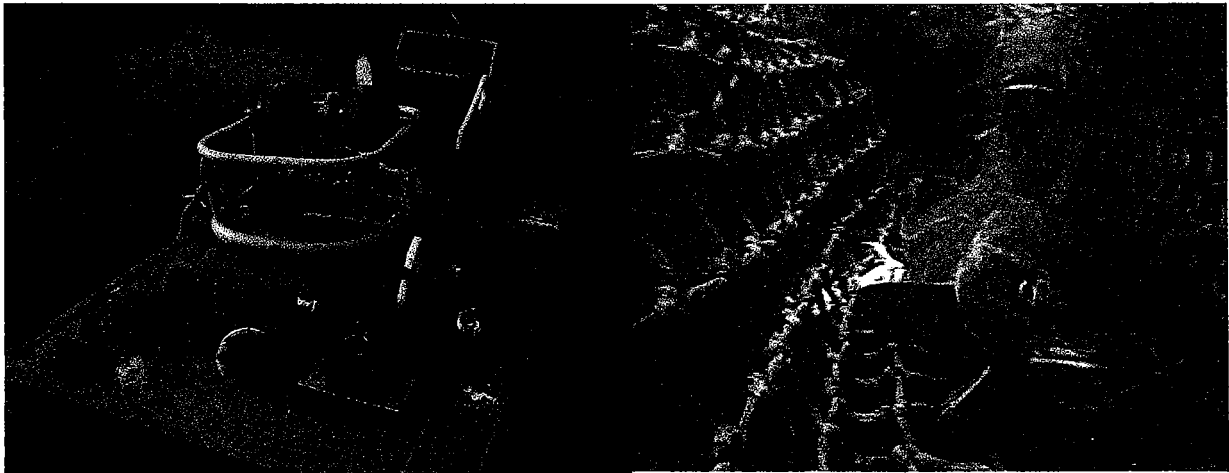

## CONTENTS

- List of Terms
- Light & Lighting
- Monitors, Recorders & Switches
- Connectors, Cables & Tethers
- Electrical
- Tape, Copying, Cases & Labels
- How to Build an Underwater Camera
- Buying Underwater Camera Equipment
- Using Underwater Camera Equipment
- Remote Operated Vehicle (ROV)
- Sunlight Versus Artificial Light
- Sunlight Penetration
- Techniques
- Tube Used to Count & Measure Fish
- Barrel Tube
- Lollipop Cod End Closing Device
- Basket to Weigh Multi-Species Discarded Fish
- Ocean Underwater Video Buoy
- How to Build an Underwater Video Buoy
- Baited Underwater Video
- Salinity, Depth & Temperature Chart
- Example of a Research Trip Report

## LIST OF TERMS

**CANDLEPOWER:** Light brightness. With more candlepower you use more amp hours of battery.

**CS MOUNT:** State-of-the-art cameras are generally CS mount. Lenses are selected to match your specific camera needs. For example, field of view and manual or auto iris.

**DEPTH of FIELD:** The area along the line-of-sight in which objects are in reasonable focus.

**FOCAL LENGTH:** Distance from the lens to the image.

**FOOT-CANDLES:** A unit of measure approximating the amount of light received by 1 square foot of surface that is 1 foot from the source of light.

**GAIN:** Any increase or decrease in the strength of electrical signal. Gain is measured in terms of decibels or number times of magnification.

**INFRARED LIGHT:** This is the area below the visible spectrum. Black and white cameras are very sensitive to infrared light. With color cameras you will need to use red filters to keep the images looking natural.

**IRIS:** The opening in the lens that allows light to enter. Irises can be either automatic or manual. Manual iris lenses are normally for internal applications where the light levels remain constant. The auto iris lens is generally used externally where the variations in light change.

**LED:** Light emitting diode. (White LED produces color similar to that of sunlight.)

**LUX:** A unit measuring the intensity of light. Full daylight sun is about 10,000 lux. A full moon is about 0.1 lux. (Extech Model 401025 & Meterman Model LM631).

**SEALED BATTERIES:** Measured in amp hours. Safest on boats.

**SEALED BATTERIES:** Measured in amp hours. Safest on boats.



## LIGHT & LIGHTING

Seawater is very clear allowing for the absorption of radiant energy, which is important for the growth of algae and other photosynthetic organisms. Red light is filtered out in the first several meters, followed by orange, yellow, green, blue and violet. Oceanic water is penetrated primarily by blue light, so the oceans are reflecting predominantly blue light. The amount of plankton and suspended solids present will reduce the amount of light that penetrates. The light that penetrates will be measured in lux and FC foot-candles (Fc). I use a Wavetex LM631 light meter on the surface and an Extech-401025 light meter mounted in a camera housing that is lowered to the sea floor with the data sensor facing up towards the surface of the water.

The example below of light was done on a clear day in the fall with the sun at 8800 Lux. The meter was reading 4000 Lux facing the deck of the boat and up to 5800 Lux looking into a clear sky. There are a lot of factors that could change these readings from day to day, but this will help you understand light penetration. Light is rapidly absorbed in the ocean. 95% of sunlight is absorbed in the upper 100m of the clearest seawater. Sunlight rarely penetrates deeper than a few meters in turbid coastal waters.

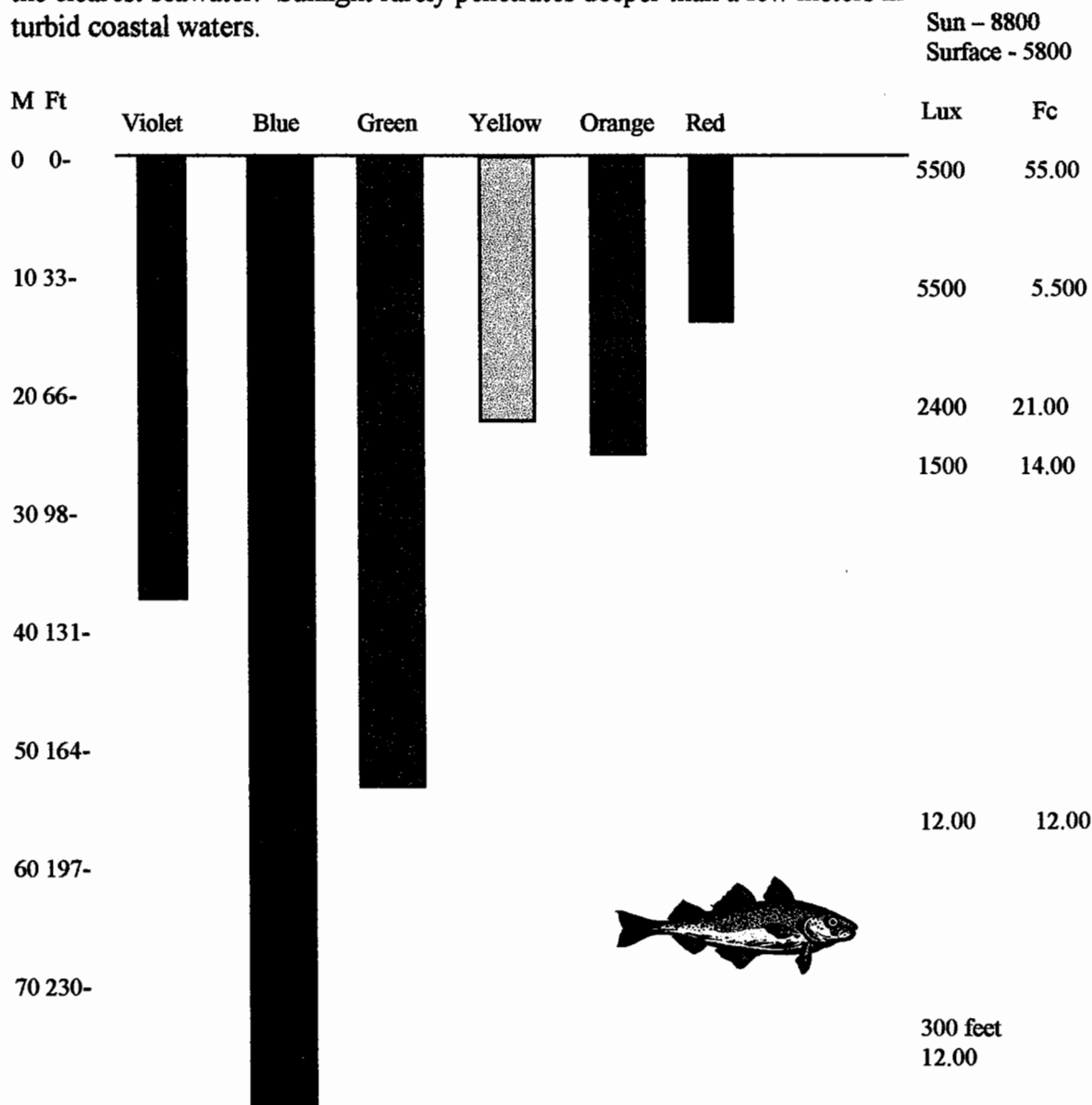

## **MONITORS, RECORDERS & SWITCHES**

Ordinary small-screen TV's are used in the field because they are readily available and inexpensive, so if they get wet or damaged it is not a great loss. But these ordinary TV's use RF (radio frequency) to get their picture and that causes some problems because they receive other signals, i.e. radio, radar, and even the propeller shaft turning. So they are ok for doing tests and viewing the underwater world, but when it comes to good, clear, no-noise viewing, you are better off with a real television monitor (Markertek and Supercircuits). A monitor will only use the signal that is coming from the cable. There are a number of 12-volt monitors for sale and they are all good. One choice is a 120 ac volt monitor. This requires that you also carry a 120 volt ac generator or use a 120 to 12-volt dc inverter. If you choose the latter, you will have what is known as 12-volt inverter noise. Most boats are 12-volt; so by using 12-volt VCR's, monitors, cameras and lights, you should be fine as long as you have good connectors and very good grounds.

If you have more than one camera in the water and only one recorder, then you will need a switch. Switches also allow you to connect time-date generators and GPS overlays to the recorder, or to send a video signal to portable camcorders.

All of the camera equipment should be mounted into a waterproof case, a very strong box or even a fish tote, to protect it while at sea. This will help keep your gear secure.

Everything must be well grounded together to reduce radio frequency noise.

## **CONNECTORS, CABLES & TETHERS**

Cables can pick up RF noise. "Noise" is occurring when there are lines across the screen and on your tapes. They always show up when you're viewing something really great. You can use standard SOW industrial cable (Home Depot) for good recording from a single camera and with cable lengths less than 300 feet. But when it comes to the lengths needed to record the marine habitat, mobile fishing gear and fixed gear (lobster gear and gill nets) in deep water, only good underwater video cable will do (Falmat). Good underwater connectors (Subconn) keep water off cable ends and allow the equipment be unplugged to make changes and for mobility.

## ELECTRICAL

This basic wiring is only a guide as all equipment comes from the manufacturer with different wiring numbers and colors.

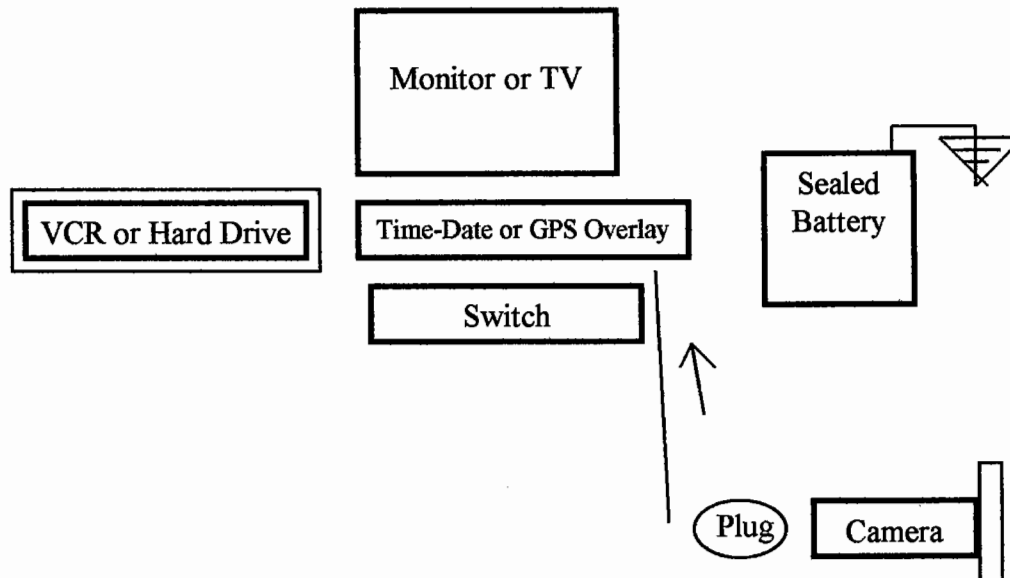

Begin with all grounds tied together. This should also include the tether shield to stop or lower signal noise. The positive should be fused, and by adding either a 12-volt LED light or a 12-volt meter you will know whether you are receiving power from your battery. By using a distribution amplifier switch (Markertek) you can bring the wiring together and tap off for other cameras. You can also distribute the video signal to a portable video camera with input video.

Next, you can add the time-date generator (Markertek or Supercircuits) or GPS overlay (Trakview). Then plug in the VCR or hard drive recorder. The cable to the monitor should be plugged into the video output in the recorder so you can see what you are recording. The better the cable the better the picture. You get what you pay for.

However, I have used the most basic, least expensive cable, cameras and recorders and still got some good footage. So don't let price be your only guide. Once you are up and running you can always change and upgrade your equipment. I still use the least expensive equipment in those situations where there is a high probability of loss. You do lose equipment just like golfers lose balls and brake clubs.

To get started you just need a camera, some cable, a TV and a battery. This can cost under \$200. The system above, using stock parts and quality equipment with about 300 feet of tether will cost under \$1,500 or can be built for about \$1,000. State-of-the-art, turnkey systems can run upwards of \$10,000. Keep all the gear clean and dry and it should last for many years. The system I built 8 years ago still works very well and is fielded for high loss tests when needed. Not that the equipment I have lost wouldn't work if someone is lucky enough to find it (42-43.10/70-45.00).

## TAPES, COPYING, CASES & LABELS

If you use good quality brand name tapes you will be happy with your video. Use a video supply house (Horizon Media Express) that sells in cases of 50. That way you will always have it in stock and the recordings will be uniform.

Tips:

1) Whenever you record something that is really good, change the tape as soon as you can and set this tape aside. You don't want to risk losing that great shot. Tapes cost so little that this practice will pay off by always having that shot on file.

2) Always put the date and the subject on your video labels. I also recommend keeping a detailed logbook of your video inventory.

Tape cases come in both plastic and cardboard (Professional Label). Cardboard is the best price and comes in different colors. Almost all case suppliers also sell side and top blank labels in packages of 10-100 sheets. With a little trial and error you can make good labels for the copies that you send out. I always ship via the U.S. Post Office because you can label the package "media" and it will ship at a lower rate. I have found over the years that it gets there in just about the same length of time as paying full freight.

Spine label

Top label

Always include tape playing  
time in minutes.

AVERY # 5199  
SPINE 2/3"x5 5/6"  
FACE 1 5/16"x31/2"

## HOW TO BUILD UNDERWATER CAMERAS

Housings can be built of mild steel or stainless steel (materials for both from McMaster-Carr). Mild steel is easier to work with but will need paint to protect the steel. The use of stainless steel will add to the cost but will pay off with a longer service life and it will be rust free.

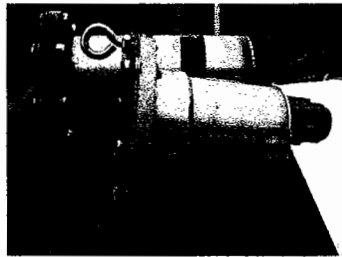

(Not to scale)

8, 1/4" Holes that bolt with 8, 1/4" 20 Stainless Cap Screws

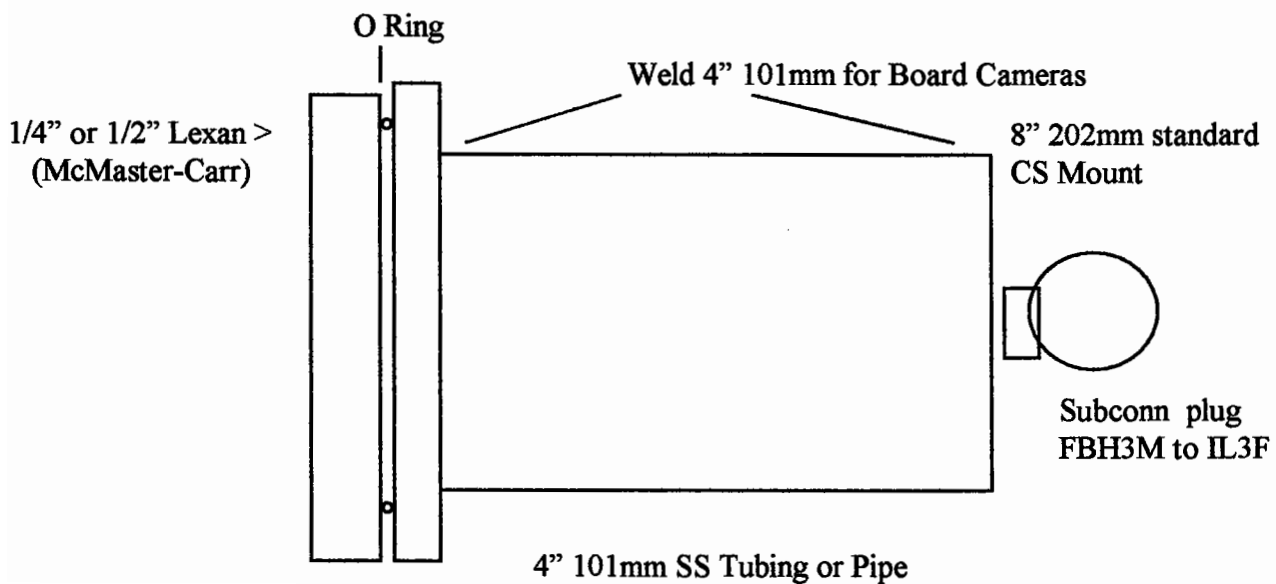
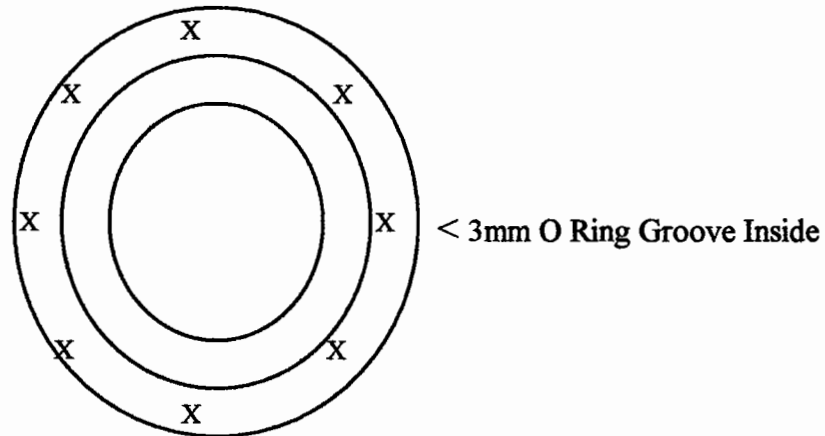

## BUYING UNDERWATER CAMERA EQUIPMENT

There are trade magazines for almost everything and underwater video equipment is no exception. Dive magazines, *Nuts & Volts* and *Sea Technology* are just a couple of examples. You can buy all the parts to build underwater camera equipment, or if you're not into building your own gear, there are many different companies that sell beginner underwater gear, very expensive gear and everything in-between.

The first thing to consider is whether to use color or black and white. With color you will almost always have to add light and after 125 feet you will need to add a lot of light to get good quality pictures. Black and white is very clear, inexpensive, and will work in most conditions.

Next, how deep do you want to go? If you're observing towed gear, how much cable do you need? With towed cameras the cable can get very expensive. Naturally, everything can be researched on the internet for price comparisons and quality of gear.

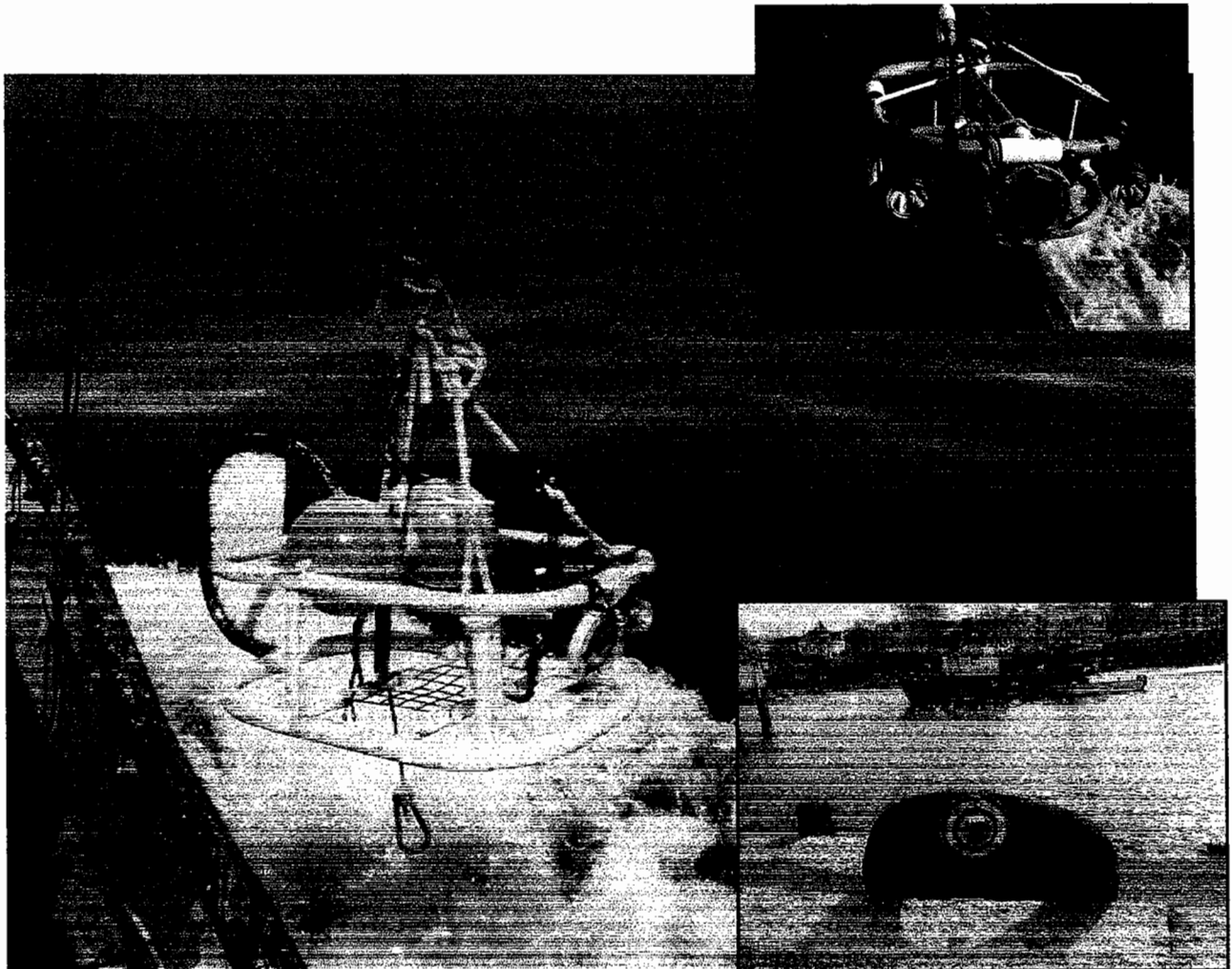

## USING UNDERWATER CAMERA EQUIPMENT

Always safety first. The setting out and hauling back of this equipment is dangerous, so put on your life vest first and take it off last. With all of the cables and lines that can be used when doing underwater video work, safety is extremely important. To help keep my cable out of the way and for ease of setting it out and bringing it in, I obtained a large reel from an old oil truck that included a 12-volt motor for reeling in long lengths of cable.

Tide, winds and currents play into how and what kind of gear goes into the water. You can sometimes compensate for the tides by adding weight. Adding fins will help with currents by allowing you to face the camera in the desired direction.

Tether and camera drag on gear being tested should be taken into account. If possible, attaching the tether to the tow cable will help reduce camera and tether drag. Both camera and tether can create bubbles as they move through the water, which may have an affect on the marine life you are trying to observe.



## REMOTE OPERATED VEHICLE (ROV)

An ROV is probably the most expensive and elaborate piece of video equipment that you can buy. But they are not without limitations. ROV's are slow and very susceptible to tides and currents. However, they allow you to remotely move around, change direction and depth and move right up to whatever it is you are observing.

Fishing vessel deck equipment, i.e. winches and davits, allows for the easy deployment and recovery of an ROV. When deploying an ROV when the vessel is not at anchor, special care should be taken to keep the tether away from the propeller. Surface current is not always the same direction or speed as the subsurface. If at anchor, swing of vessel and tide need to be watched closely.

Vessels engaged in marine research should also display day and night signals to inform other vessels when working in congested waterways.

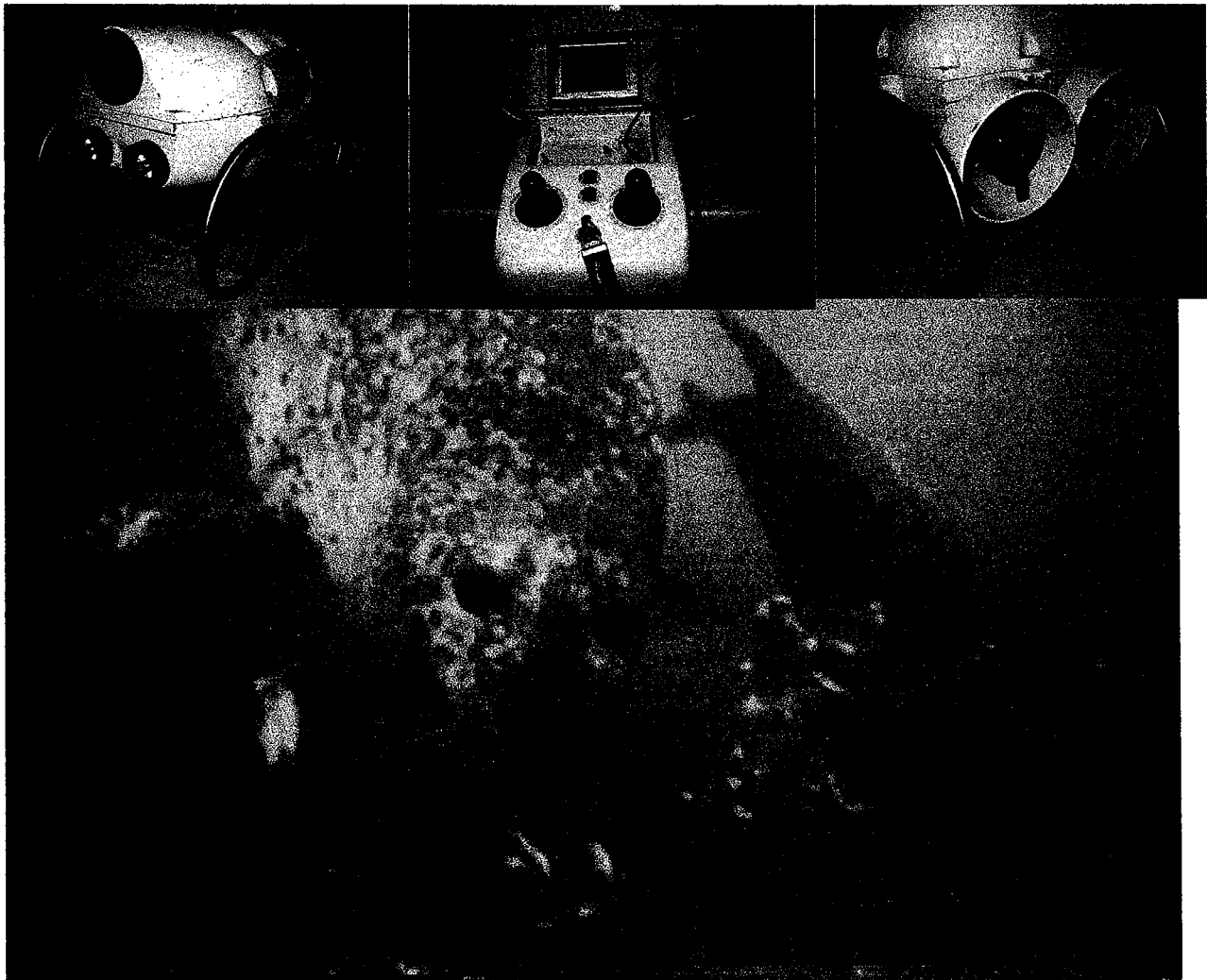



## SUNLIGHT VERSUS ARTIFICIAL LIGHT

Sunlight loses its candlepower as you go deeper, so at night, on cloudy days and in deep water you must add light. When adding light remember that fish react to it. But if you're just observing gear you should add as much light as you can for best quality video and pictures. We use both incandescent, 35, 50 and 100 watt halogens and a variety of LED lights. With standard 50 watt 12-volt bulbs the output of candlepower is good but you must use a lot of amperage to keep these lights at full brightness. We use LED lights that consume about 25% of incandescent light amperage. LED lights are very cold and reaction to the light from fish is minimal. Below are some findings to use as a guide.

By using a Wavetek LM631 digital light meter, held one foot from the end of each light source and taking its peak beam reading in foot-candles (FC), we measured the approximate amount of light received by the meter. Lux is Fc multiplied by 10. All lights are 12 volt or are diver's flashlights that use AA or C cell batteries.

• Single LED red	0.03
• Single LED yellow	0.03
• Single LED green	0.07
• 10 white 12 volt LED bayonet-based bulb	13.06
• 12 volt bright red 22-bulb LED	47.5
• 12 volt single red 6-bulb LED	13.55
• 12 volt four amber with 4-bulb LED	20.1
• Princeton dive light single LED	11.8
• Princeton dive TEC-40 white incandescent	0.97
• 12 volt 50 watt Halogen	67.0
• Regular flashlight 2 D-cell	0.15
• Tektite Expedition Star	331
• Cluster of 4 LED's, 10 lights each	60.4

The more light there is the more amperage you will use. The best video is achieved with the most light.

## SUN LIGHT PENETRATION

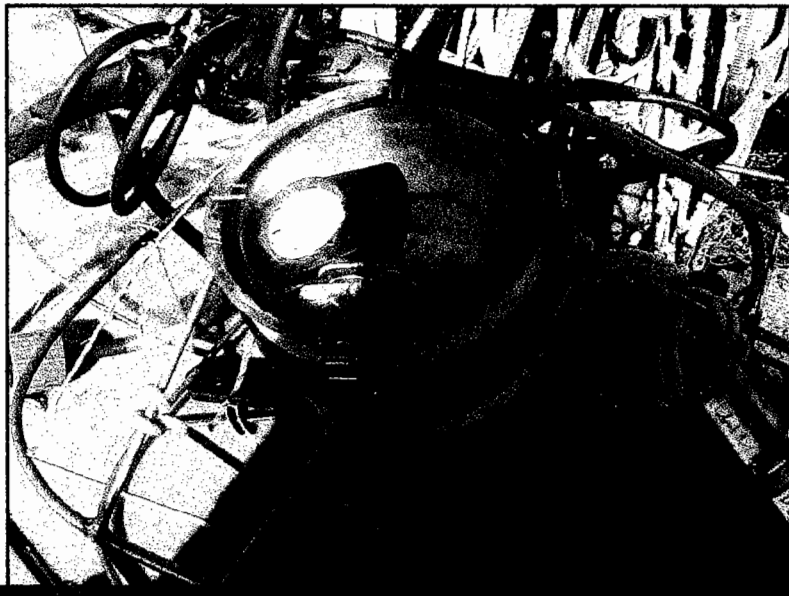

Using Wavetec LM 631  
On the surface and a  
Extech 401025 light me-  
ter mounted in a stainless  
steel housing sun light  
was measured from the  
surface

2', 33', 66', 100', 200', and  
300' feet to find the re-  
duction of sun light  
( on going)

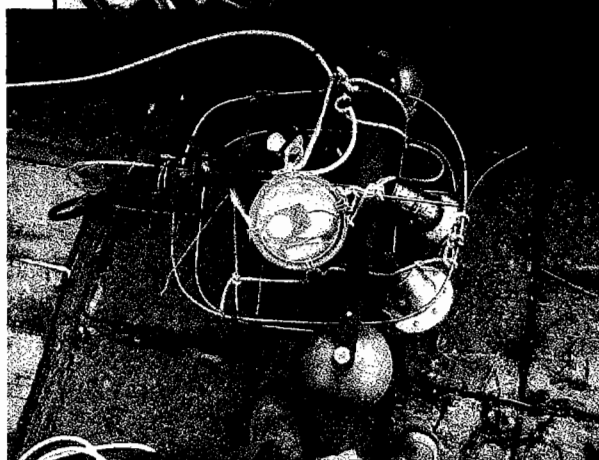

## TECHNIQUES

Add a fin to rear of camera to help direct camera.  
Add weights to keep camera and tether stable as  
speed and/or drift increase.

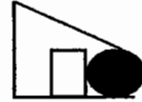

For dredges, mount camera on main tow bar of dredge.  
Scallops or clams can be observed without  
interference of mud and rocks.

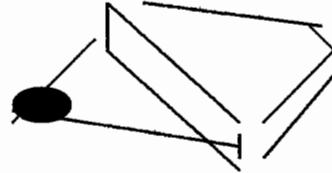

Trawl head ropes are stable when towing and a  
camera mounted there can observe both foot rope  
and fish.

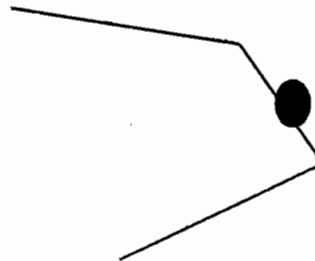

Camera mounted about 3 feet over lobster traps with  
PVC pipe allows viewer to observe lobster in and  
around trap.

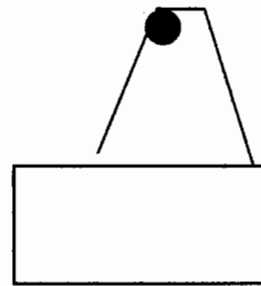

Clamp camera to pole to view hull and propeller.

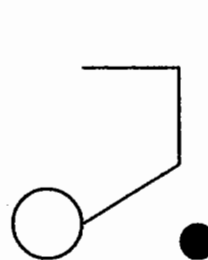

## STEEL TUBE USED TO COUNT AND MEASURE FISH

The tube is constructed of 1-1/2" steel mesh wire, 48" long by 32" across, with a small ramp to guide fish in front of the camera and measuring board. Floats were added as needed and the unit was sewn into the end of the extension of the fish net. Fish were released on the bottom after testing with the addition of a lollipop.

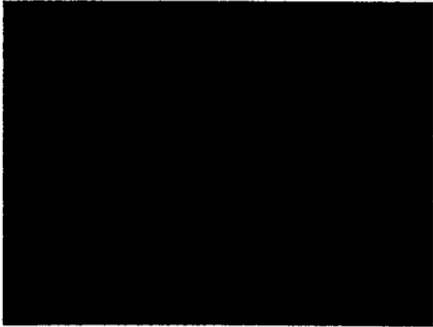
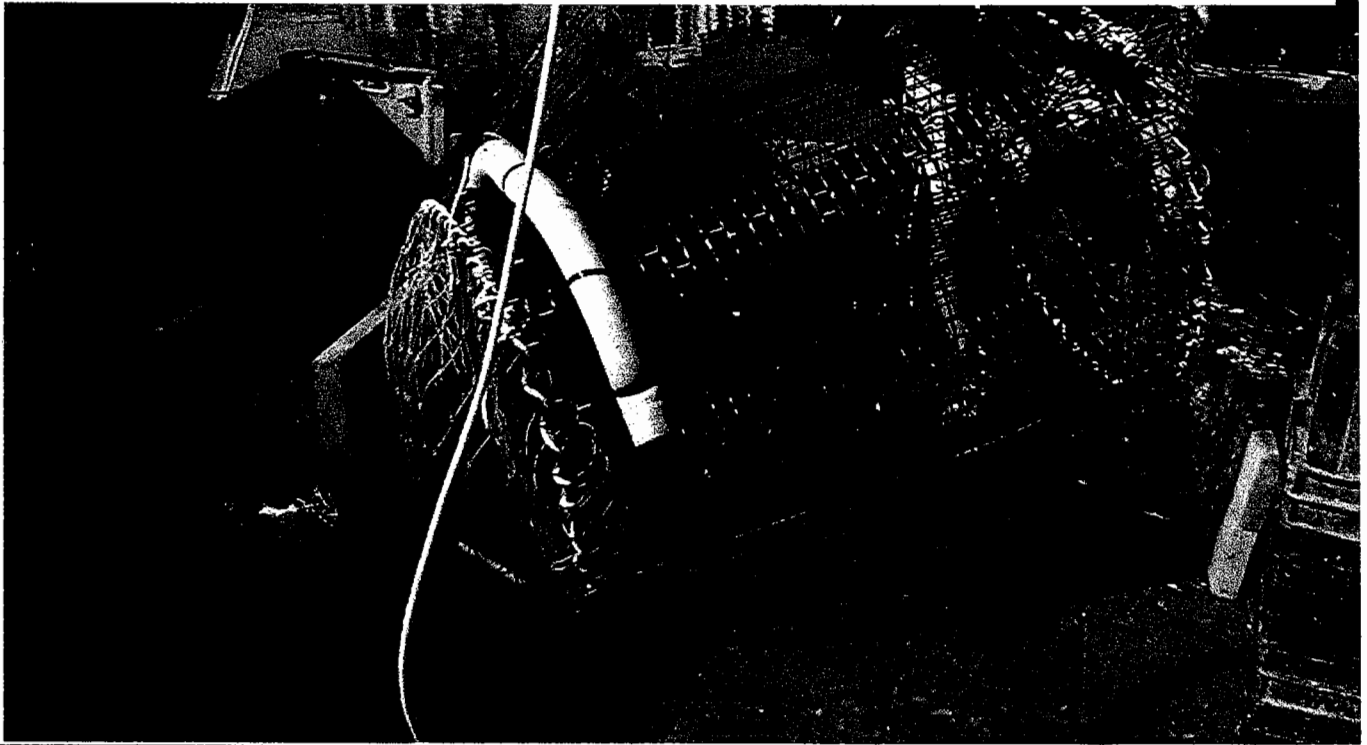

Cod end closed with lollipop

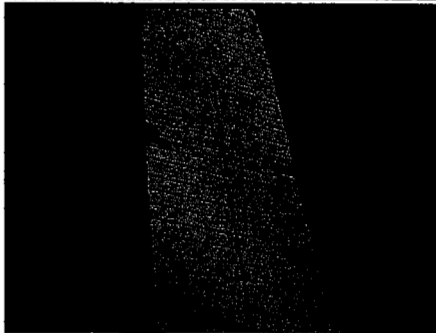

Measuring board



Ramp



After about 30 minutes cod end opens.

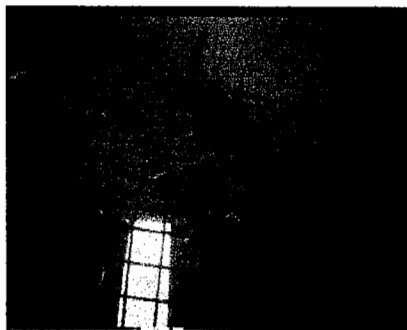

All but one fish escaped.

## BARREL TUBE

A simple white plastic barrel is attached to the end of the cod end to count fish escaping. Fish escape so rapidly that counting them is difficult. A short cod end was added with a lollipop to hold fish back for counting and measuring. A 55 gallon barrel is used with both ends cut out and 1/2" holes drilled to attach twine. At the front of the barrel a video camera is attached and used both with and without lights.



On deck

Measuring boards

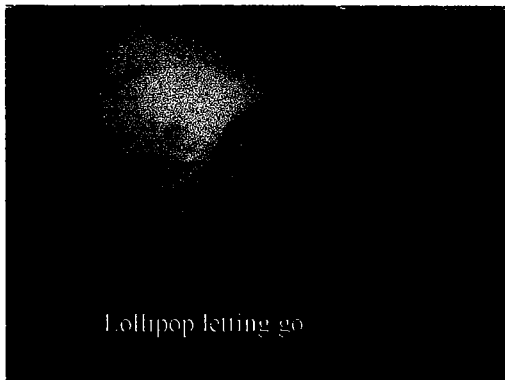

Lollipop letting go

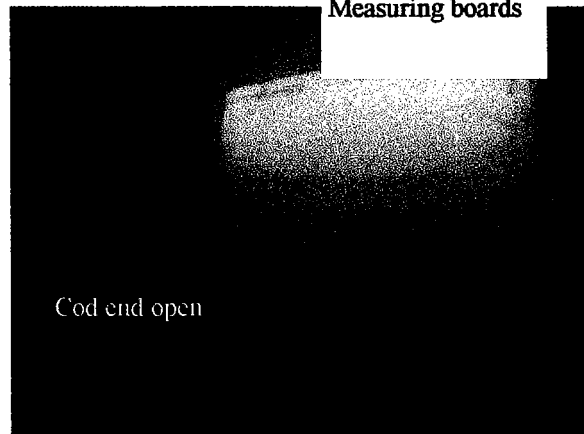

Cod end open

## LLOLIPOP COD END CLOSING DEVICE

To reduce the mortality of fish caught while engaged in fish net research, a lollipop was used with a small door spring to hold the cod end closed. After approximately 28 minutes the lollipop dissolved and the cod end opened letting the fish escape unharmed and at the depth in which they were caught. With the outside wrapper left on it took about 38 minutes. Sugar Daddy's lasted 50 to 55 minutes.

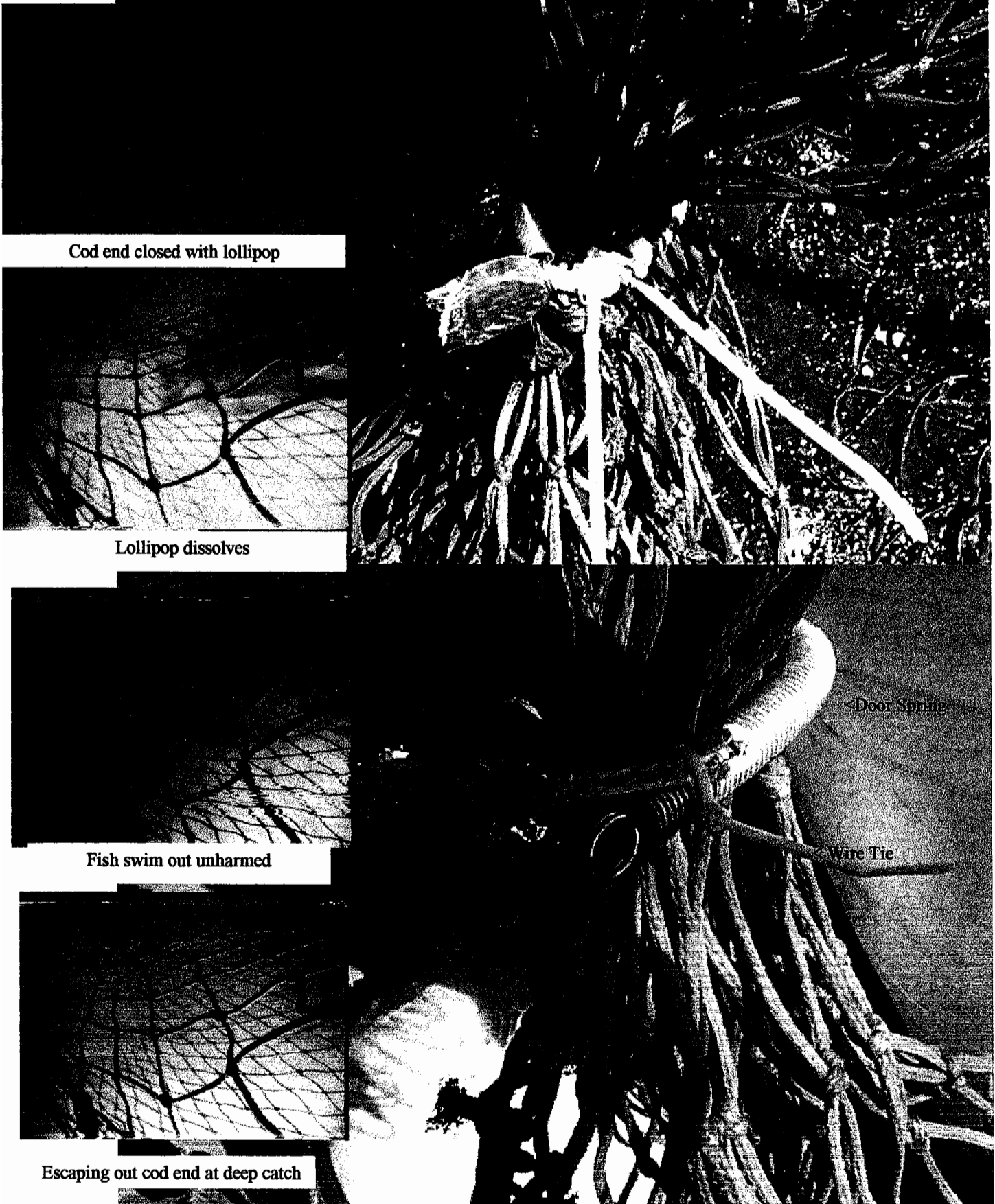

Cod end closed with lollipop



Lollipop dissolves



Fish swim out unharmed

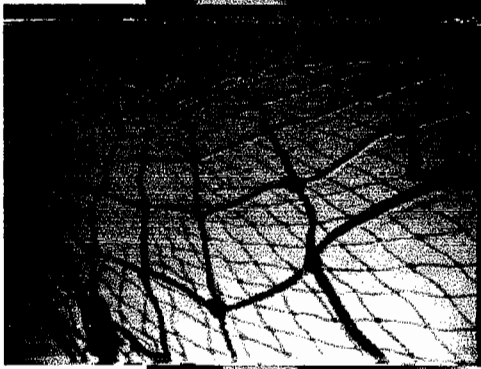

Escaping out cod end at deep catch

Door Spring

Wire Tie

## BASKET TO WEIGH MULTI-SPECIES DISCARDED BY-CATCH

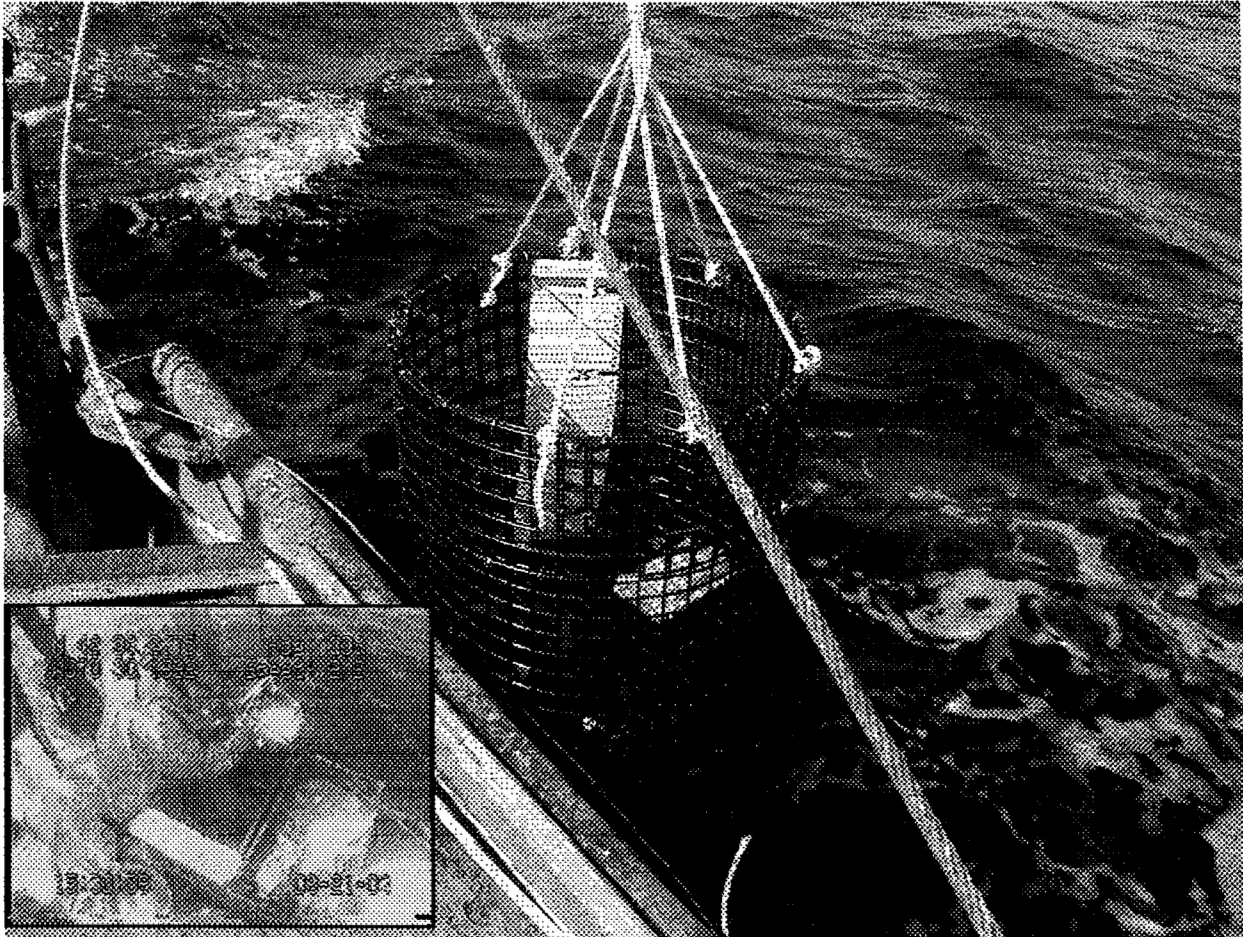

The basket was designed and built to weigh the by-catch discarded by multi-species vessels and to work in conjunction with video cameras on deck. The cameras are hooked up to the vessel's GPS so data on 10 functions can be recorded at one time when no observer or crew are on board during normal fishing and data collection days. Two temperature data loggers are used; one attached to the net and one for surface temperatures. Both loggers record time and temperature so a simple but accurate catch-per-unit effort (CPUE) is recorded.

Recorded by video and temperature loggers:

- Date
- Time set out
- Location
- Speed
- Direction
- catch
- Total weight of discard
- Surface temperature
- Bottom temperature
- Time hauled back

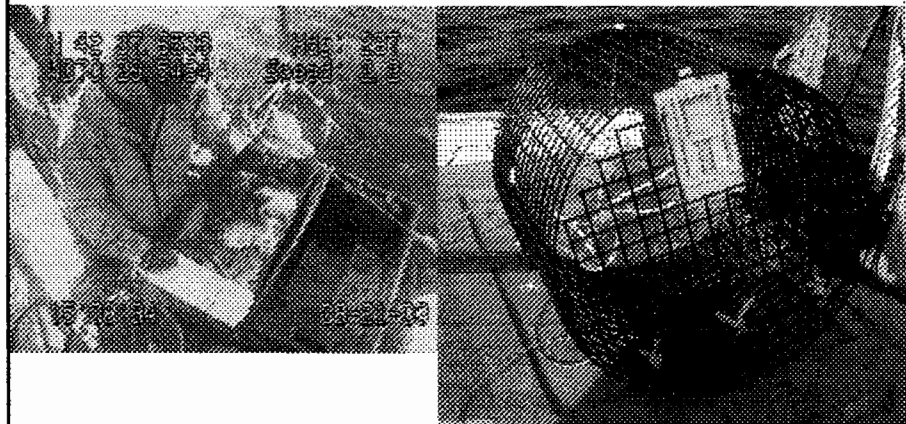

The basket is of 1" square steel mesh wire rolled to a 16" outside diameter by 15-1/2" deep. The basket holes the approximate equivalent of one standard fish basket. The bottom of the basket has a trap door installed for ease in emptying when the basket is full. The basket is suspended overboard with a 100 pound scale that also records the maximum weight.

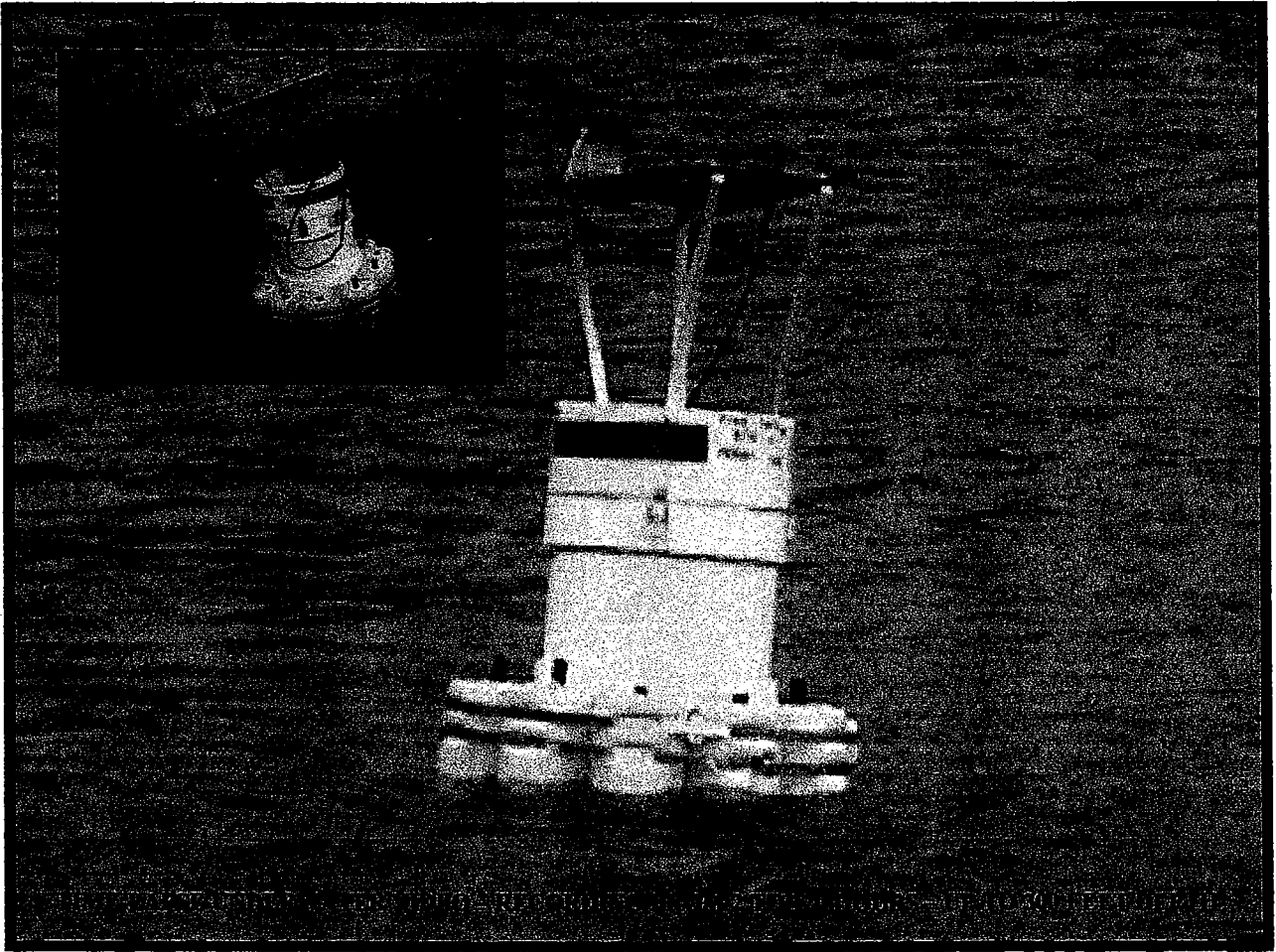

ON STATION FOR DAY AND NIGHT STUDY

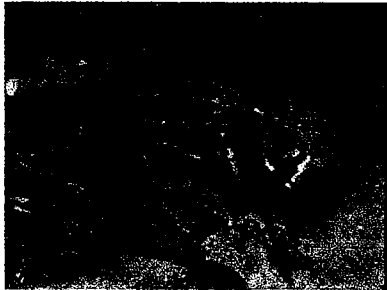

LOBSTER HABITAT

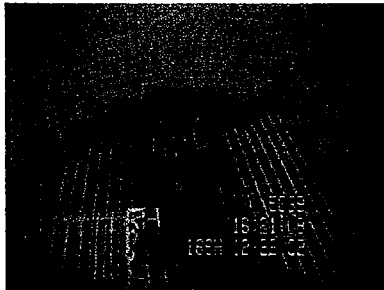

COD TRAPS



SEAL AND LOBSTER TRAPS



FISH HABITAT



LOBSTER MIGRATION



BOTTOM FISH



1/4X2 LIFT BAR BOLTED TO  
COUPLING 24 INCH HIGH  
(ROSE MARINE)

WATER TIGHT ENDS (MJ STEWART INC)  
BH3F, M, ILEF & DLSA KIT

FLASHING ANCHOR  
LIGHT-9 VOLT BATTERY  
(ROSE MARINE)

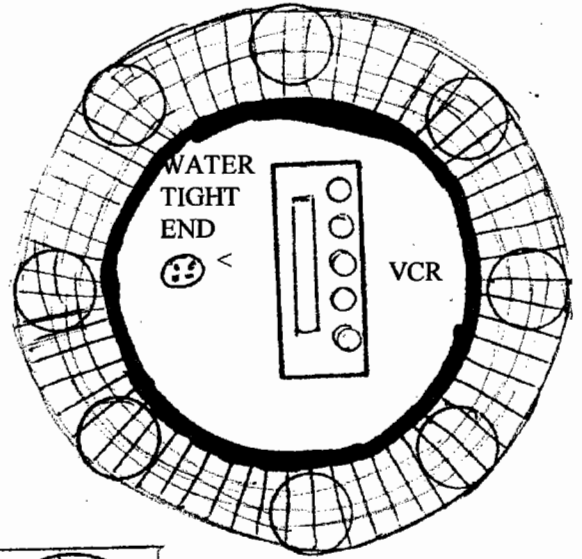

CUT AND FIT 1/2 LEXAN COUPLING  
INSIDE OF 12 INCH PVC COUPLING  
ADHESIVE LEXAN TO INSIDE OF RIM  
DRILL AND FIT BH3F (MODERN PLASTICS)

4 STAINLESS #1794A43 DRAW LATCHES  
(McMASTER-CARR)

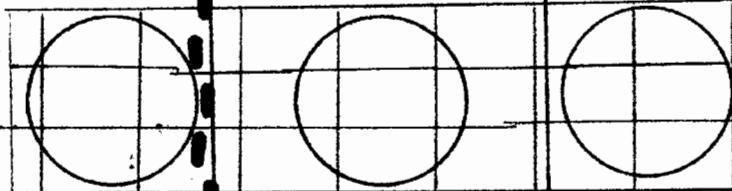

8 inch trawl floats  
Lobster trap wire  
(WINCHESTERS  
FISHING GEAR)

1/2 GASKET IS FIT BETWEEN  
LEXAN AND TOP OF 52 INCH  
LONG 12 INCH PIPE 4 EQUALLY  
SPACED LATCHES ARE USED TO  
HOLE COUPLING TO PIPE . BAT-  
TERY IS MOUNTED TO BOTTOM  
WITH STRAP AND REMOVABLE  
RAKE TO HOLD VCR.

12 PVC , CAP, & CEMENT  
(WEBB)

CEMENT CAP

<12 pipe cap

< 1/4 steel plate with 3/8 hole in center

3/8 s.s. eye bolt with sealant

Tether (Falmat Inc.FM070901-

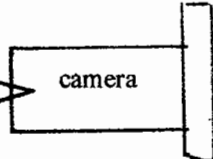

# Baited underwater video for assessing fish abundance

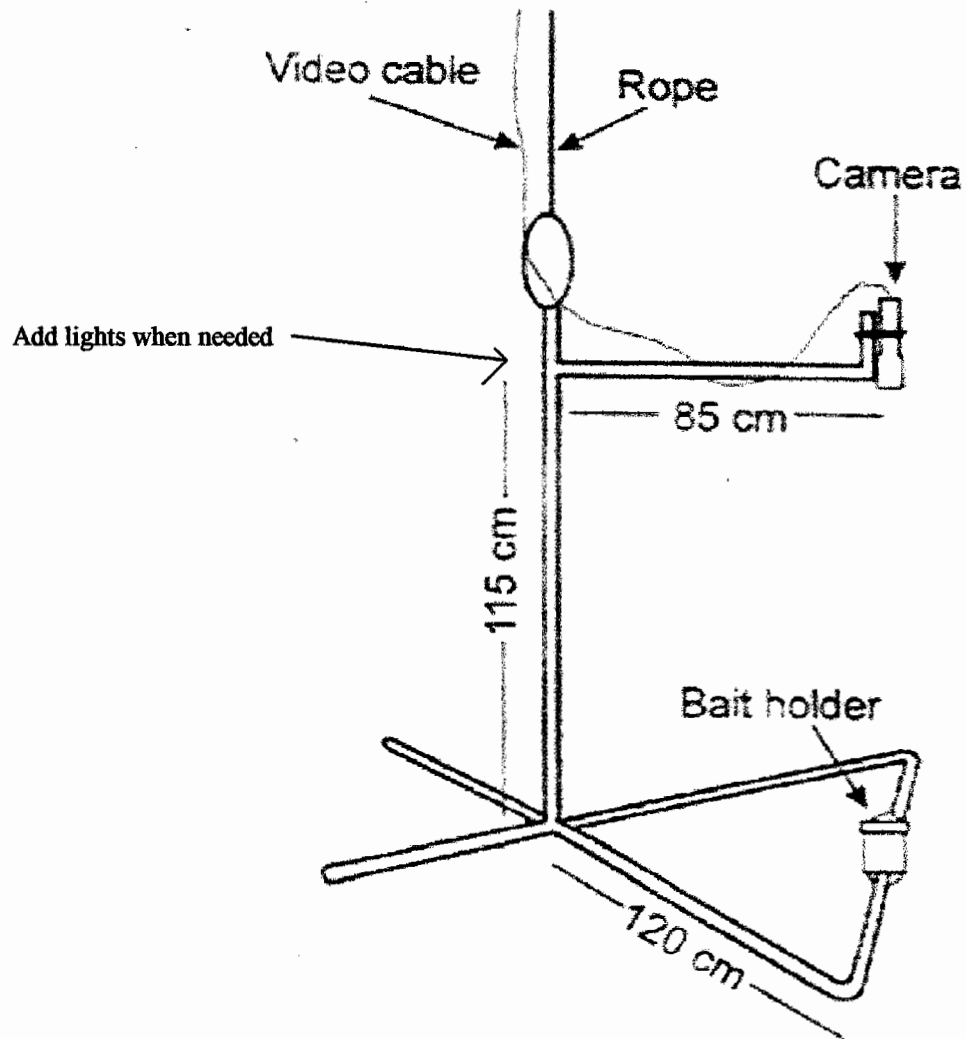

# FISHING VESSEL RESEARCH TRIP REPORT

VESSEL NAME

VESSEL NUMBER

DATE

---

FISHING GEAR                      MESH SIZE                      SURFACE TEMP.                      BOTTOM TEMP.

DOOR WEIGHT                      GROUND GEAR LENGTH

SALINITY

---

LAT & LONG OR LORAN      ENDING LAT & LONG                      CREW NUMBER  
13                                      13                                      SPEED  
25                                      25                                      AVERAGE DEPTH  
44                                      44

---

FIRST TOW:    TIME SET OUT                      TIME HAUL BACK                      TOW TIME

---

APPROXIMATE CATCH WEIGHT                      BY-CATCH DISCARD WEIGHT\*\*

---

SECOND TOW:    TIME SET OUT                      TIME HAUL BACK                      TOW TIME

---

APPROXIMATE CATCH WEIGHT                      BY-CATCH DISCARD WEIGHT\*\*

---

THIRD TOW:    TIME SET OUT                      TIME HAUL BACK                      TOW TIME

---

APPROXIMATE CATCH WEIGHT                      BY-CATCH DISCARD WEIGHT\*\*

---

FOURTH TOW:    TIME SET OUT                      TIME HAUL BACK                      TOW TIME

---

APPROXIMATE CATCH WEIGHT                      BY-CATCH DISCARD WEIGHT\*\*

---

TOTAL LANDED WEIGHT:                      TOTAL DISCARD WEIGHT: